

THE SYMMETRICAL MICROPHONE CAPSULE AND THE QUEST FOR THE PERFECT “ACOUSTIC WINDOW”

JOHN WILLETT *MInstSCE MBKS MIBS MAES*

Technical Manager, Sennheiser UK Ltd.

The microphone, as the very first link in the chain, is the most important part of the recording and reproduction process. As such, it ought to be as neutral as possible, an “acoustic window” neither adding to nor subtracting from the original. However, microphones can introduce noise and other non-linearities that distort the original signal. We will look (and listen) at these distortions and show how a symmetrical transducer can minimise these non-linearities and more closely approach that ideal “acoustic window”.

1. INTRODUCTION

There are, I suppose, two main philosophies in microphone design. One says that a microphone is like a musical instrument with its own particular character. The other says that a microphone should be like an acoustic window, neither adding nor subtracting anything, but passing the sound through as if it was not there. Both of these philosophies have validity, but it is with the latter that I am going to dwell on now.

Digital recording is putting more and more demands on the microphone, deficiencies which were masked by earlier analogue techniques can now clearly be heard by the listener with even an average hi-fi system.

These deficiencies are mostly inherent noise and distortion caused by non-linearities in the microphone.

If your philosophy says that a microphone has its own character, you may be able to live with some of these deficiencies if their effect is a sound pleasing to your ears. However, if you are striving for the perfect acoustic window, anything that alters the sound in any way has to be eliminated.

Of course, perfection is impossible for anyone but God himself; but if your philosophy says that the sound should not change, perfection is something you must always strive for.

2. THE PROBLEM

Before the advent of digital recording, microphone deficiencies were masked by the analogue recording process. For example, by the inherent tape noise (hiss), modulation noise, tape saturation, etc., not to mention the compounding of these inherent distortions by tape copying, record mastering, pressing, etc..

Digital recording, by contrast, is very revealing of any deficiencies in the recording chain, especially with modern high-resolution systems.

The demands on a studio microphone are thus:-

- Wide frequency response
- Flat frequency response
- Frequency independent polar pattern
- Low noise
- Low distortion
- Wide dynamic range
- High sensitivity

Conventional condenser microphones already display some of these properties. The low diaphragm mass makes for a sensitive microphone, however the damping required to make a flat frequency response can reduce this. RF condenser microphones have added advantages in that they have a drastically reduced electrical impedance which is constant for all audio frequencies, no high impedance FET is required, the noise floor is low, sensitivity to humidity is also low and the output is fully balanced without having to revert to a transformer or balancing circuit.

Although this may be a good start, it is not enough.

Microphones have inherent non-linearities, which distort and change the recorded sound.

3. THE INVESTIGATION

To measure these non-linearities, various microphones from several manufacturers were subjected to tests to determine the extent of the problem.

The test consisted in placing the microphone under test in an anechoic chamber. Two loudspeakers were used to replay two pure tones at equal volume 70Hz apart. These two tones, of 104dB SPL each, kept at a 70Hz separation distance, were then swept through the frequency spectrum from 200Hz to 18kHz and the results plotted. These are shown in fig.1.

Fig.1: Correlation of frequency and intermodulation distortion

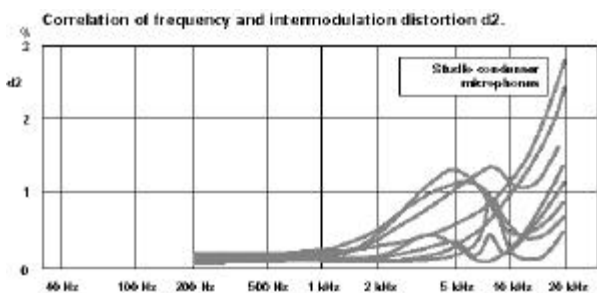

Although all microphones display very good characteristics at lower frequencies this “double-tone distortion” rises at higher frequencies with two microphones having over 2% distortion (one almost 3%) at 18kHz, and every microphone having over 1% distortion at some frequency along the line.

What is the cause of this non-linearity?

Fig.2 shows a simplified diagram of a condenser microphone capsule. The diaphragm and back-plate form a capacitor, the capacity of which depends on the width of the air gap. From the acoustical point of

view the air gap acts as a complex impedance. Unfortunately, this impedance is not constant but depends on the diaphragm excursion. Its value increases when the diaphragm is moved towards the backplate and decreases when the diaphragm moves in the opposite direction. The air gap impedance is thus varied by the motion of the diaphragm. However, you will see that the air gap behind the diaphragm will impose some reverse pressure on the diaphragm as it is compressed (albeit that the backplate is effectively an “open” design) whereas the air gap in front of the diaphragm can effectively be called infinite.

Fig.2: Normal single-sided transducer

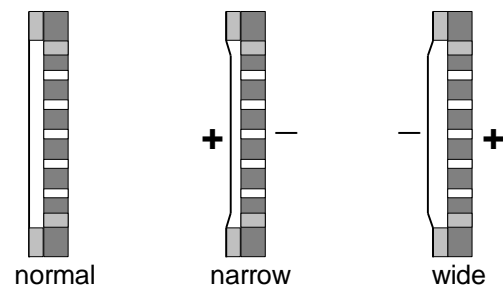

4. THE SOLUTION – Part 1

In order to improve the linearity a push-pull capsule was designed (fig.3). An additional “back-plate” identical to the back-plate is positioned in front of the diaphragm. Thus two air gaps are formed with equal acoustical impedance as long as the diaphragm is in its rest position. If the diaphragm is moved by the sound signal, both air gap impedances are deviated opposite to each other. The impedance of one side increases while the impedance of the other side decreases in direct relation to it.

Fig.3: Symmetrical push-pull transducer

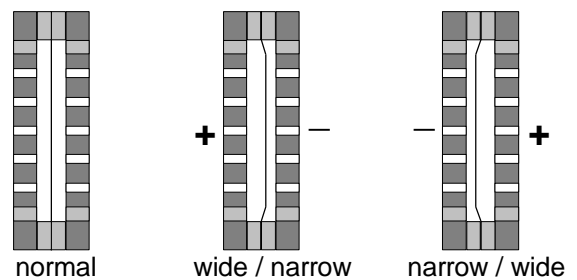

The variation effects compensate each other regardless of the direction of the diaphragm motion and the total air gap impedance remains constant.

The result of this push-pull capsule design is a drastically reduced distortion figure in the microphone, as is shown by the result in fig.4.

Fig.4: Correlation of frequency and intermodulation distortion (push-pull transducer)

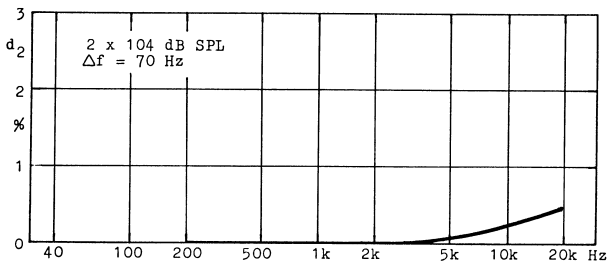

The realisation of this capsule design is shown in the capsules of the MKH 20-80 series of microphones.

Fig.5: MKH 40 microphone capsule



Superimposing the results of fig.4 onto the results of fig.1, the improvements in this capsule design can clearly be seen (fig.6).

Fig.6: Correlation of frequency and intermodulation distortion (combined results)

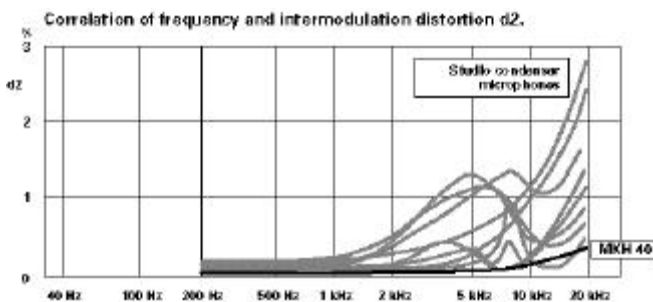

Whereas originally the distortion figure was approaching 3% for one microphone at 18kHz, with the push-pull capsule design this figure is now only about 0.3%.

But so far, all you have heard is me speaking. The proof, as they say, of the pudding is in the eating – so let us now listen to the results.

5. DEMONSTRATION

What I am going to play you now is a demonstration of the non-linearity in condenser microphones and the improvement that the push-pull transducer makes.

We will be hearing three different microphones: a large diaphragm microphone, a small diaphragm microphone and a push-pull symmetrical capsule microphone.

In this demonstration each microphone was placed in an anechoic chamber, two pure tones were played through loudspeakers and recorded. Depending on the extent of the non-linearity, a microphone produces a new additional signal component (a bit like the intermodulation effect in radiomicrophones) with a frequency equal to the difference between the two sounds. To guarantee that the test signal itself has no difference frequency distortion, the two tones are transmitted separately through two loudspeakers. The two signals are at about 5kHz and differ from each other by 100Hz. The sound pressure levels amount to 114dB each, for a total sound pressure level of 120dB.

We start by listening to the large diaphragm microphone. You will first hear the microphone's output signal, it sounds rather dissonant. Despite this, please concentrate on the low frequency difference tone in the background.

{ Audio Demonstration from CD }
Tr. 3-6, Total dur: 6'18"

However, the symmetrical push-pull transducer, although enabling a very large improvement in linearity, is not the complete answer.

6. LOW NOISE – HIGH SENSITIVITY

I spoke earlier, in passing, about damping being used in a microphone design to achieve a flat frequency response. Although this does give the required result, it has the side effects of reduced sensitivity and higher noise.

In our quest for the perfect acoustic window, we do require a sensitive microphone, and noise is something we can certainly do without.

If we could, however, design a transducer with low damping we could increase the sensitivity and lower the noise floor. This is shown in fig.7.

Fig.7: Damping

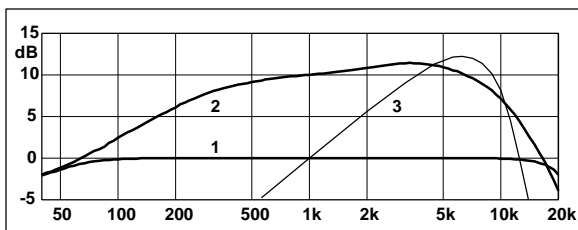

- 1) Standard transducer design with high damping for a flat frequency response
- 2) Transducer design with low damping for increased sensitivity and low noise
- 3) CCIR noise weighting curve for comparison (spectral noise sensitivity of human hearing)

You will, no doubt, notice that although the transducer with low damping has an improvement of about 10dB, its frequency response is anything but flat.

7. THE SOLUTION – Part 2

The inherent noise in condenser microphones is caused partly by the random incidence of air particles at the diaphragm due to thermal movement, partly by frictional effects in the resistive damping element and partly by circuit noise.

As this paper is focusing on the symmetrical capsule design I will not elaborate on this too much here.

The noise performance of RF microphones is inherently superior to that of AF microphones, this is mainly due to the electrical impedance of the capsule. Electrically the transducer is acting as pure capacitance, its impedance decreases as the frequency increases. The capsule impedance is low in an RF microphone but high in an AF microphone. In an RF circuit the electrical impedance of the capsule is constant due to the fixed frequency of the RF-oscillator, whereas in an AF circuit it varies with the audio frequency, giving very high values, especially at low frequencies. Because of this, resistors of extremely high value are needed at the input of the microphone circuit of an AF microphone to prevent electrical loading of the transducer – unfortunately generating additional noise. By contrast an RF microphone capsule has a very low output impedance, the output signal can thus be fed directly to normal bipolar transistors which enable an excellent noise performance.

Starting with this, already good, noise performance of the RF microphone capsule and the 10dB further improvement achieved by the low damping (curve N° 2 in fig.7 above) it is relatively simple to design a corresponding frequency correction circuit to give, not

only a flat frequency response, but also high sensitivity and low noise (fig.8).

Fig.8: Equalisation

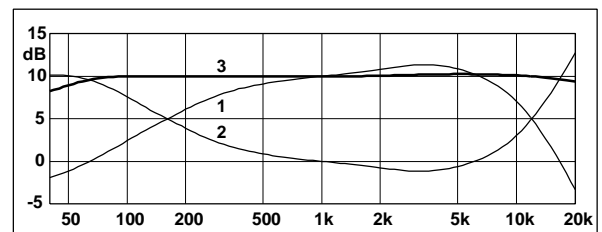

- 1) Natural frequency response of **transducer** (capsule)
- 2) Correcting frequency response of **circuit**
- 3) Resulting frequency response of **microphone**

Again, you have been listening to me tell you the theory, let us now listen to the results.

{ Audio Demonstration from CD }
Tr. 7-8, Total dur: max. 6'43"

With this microphone design we have achieved not only extremely low distortion and a high level of linearity, but also a sensitive microphone with a very low noise floor.

Fig.9: Inherent noise (MKH 40)

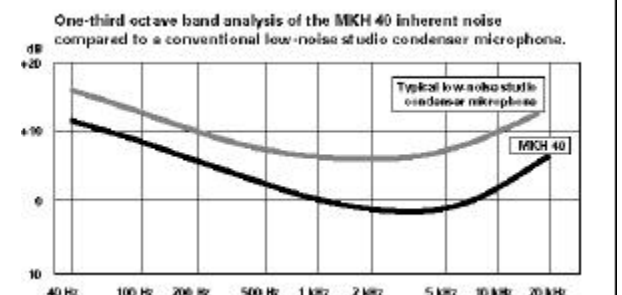

Theory apart, the following diagram shows the frequency response of a production microphone – the cardioid MKH 40.

Fig.10: MKH 40 Frequency response

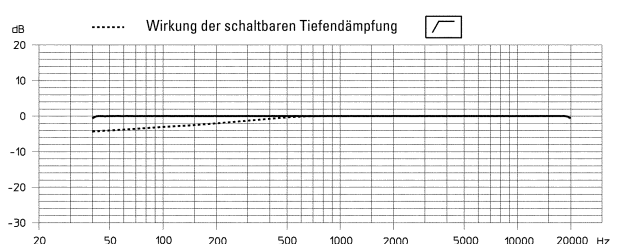

As you can see, the flat frequency response has been achieved in practice; and, no, I didn't draw it with a ruler.

But a flat frequency response is not everything, the ability of a microphone to be consistent at all recording angles is also extremely important.

The following diagram is the polar pattern of the same cardioid microphone.

Fig.11: MKH 40 Polar pattern

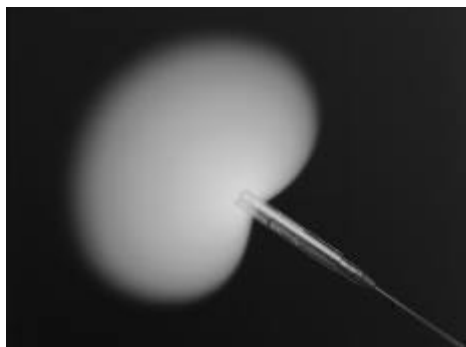
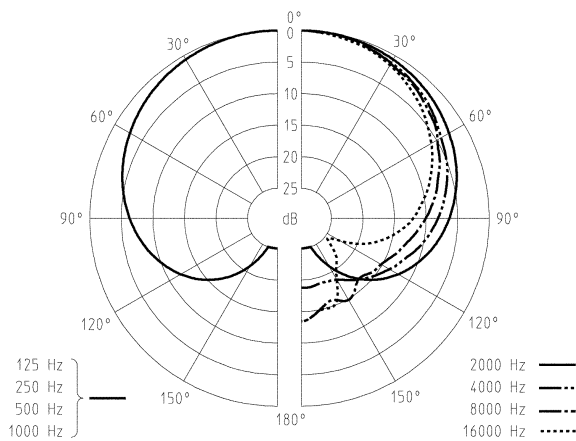

This is very close to the ideal cardioid pattern. Its deviation is only at higher frequencies where it rolls-off predictably and smoothly.

In my own opinion the MKH 40, although excellent, is one of the worst in the range (due, I suppose, to its very high frequency response between 120° and 180° off axis), the figure-8 and super-cardioid patterns are even closer to the ideal. Though my personal favourite is probably the omni-directional, whose deviation from the ideal is smooth and predictable and due only to the masking effect of the physical size of the microphone housing.

Fig.12: MKH 20 Omni-directional polar pattern

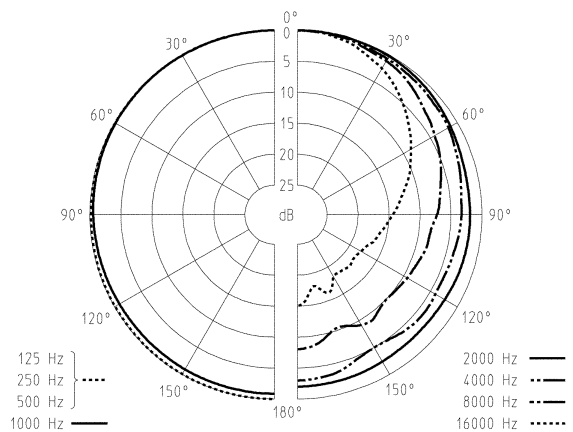
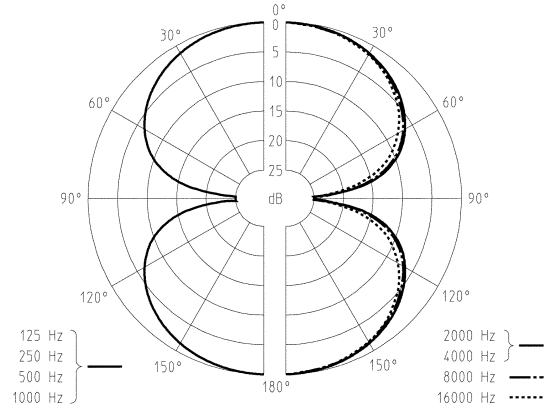

Fig.13: MKH 30 Fig-8 polar pattern



The figure-8 microphone is a true single diaphragm design, totally symmetrical due to the push-pull capsule design. It is the only figure-8 condenser microphone on the market, which is truly a single diaphragm symmetrical design. All other figure-8 microphones are either achieved by out-of-phase back-to-back cardioids or by a single diaphragm with an acoustically open back plate (with the corresponding problems described earlier – fig.2).

8. CONCLUSION

I hope I have shown that, although not yet perfect, the symmetrical push-pull capsule design is a large step forward towards reaching that ideal “acoustic window”.

If I were honest, which I am, I would say that my objective in presenting this paper is to persuade you to take a second look (if look is the right word) at the tools (ie: microphones) you are using.

Why do you use the microphone you do? Is it because you like the sound? Is it because someone told you it was the best one to use? Is it because “everyone else uses it”? Or is it because.....?

If you are trying to create a sound image, you will chose the microphone that gives you the sort of sound you are looking for.

If, on the other hand, you are wanting to capture a performance; then you will want a microphone that will capture that sound without adding or subtracting anything (or at least as little as possible).

My purpose today is to demonstrate what non-linearities in a microphone can do, how they distort and change the sound, and how, in the symmetrical push-pull transducer design, we have attempted to minimise these distortions and to come as close as modern technology will allow, to that elusive “acoustic window”.

After all, the microphone is the most important part of the recording and reproduction process. It is the very first link in the chain, that vital part that changes acoustic energy into electrical energy, what is lost here cannot be regained later. If this link in the chain is not right, it will degrade forever all that follows.

However, I will put my money where my mouth is, and conclude by letting you take a short listen to a few of my own recordings made with MKH symmetrical capsule microphones. These recordings were made without any extra processing equipment – just two microphones fed into a digital tape recorder.

9. MUSICAL WORKS

The first piece I am going to play you is a piece of new choral music. The composer is James Cook and this is one of several pieces I recorded for him in Oxford recently. The choir is from Merton College, and the recording was made in the college chapel. An MKH 30 and 40 were used in M/S configuration and recorded using the new TASCAM DA-45HR 24-bit DAT recorder.

“Sacred Choral Music of James Cook” Tr. 8 I am the way, the truth and the life - 4’16”

The second piece I am going to play you is a piece of piano music by Erik Satie. This is his well-known Gymnopedie N° 1. The pianist is John Lenehan – who, as well as playing solo works, often accompanies Julian Lloyd-Webber and Nigel Kennedy. I recorded this with a pair of MKH 20 omni-directional microphones. The piano was a Steinway concert grand, and the location was Farnham Maltings in Surrey.

“The Son Of The Stars” Tr. 14 Gymnopedies 1 - 3’04” (Tr. 9 on Demo CD)

I recorded this about eight years ago and the CD was released in 1992. I *was* going to say that this was on a small label with a small circulation. However, Classic FM has re-released it in their “Full Works” Series. It is now available on the BMG label, N° 75605 57022 2. And I have been told that it has received rather a good review.

The next piece is also piano music. This time by Frédéric Chopin, it is his Nocturne N° 10 in A flat major. The pianist, this time is Richard Meyrick. Again, a pair of MKH 20’s were used.

Chopin “The Complete Nocturnes” Tr.10 Nocturne N° 10 in A flat major (Op.32 N° 2) (Tr. 10 on Demo CD)

This is from a double CD, released a couple of years ago on the Cirrus Digital Classics label.

Lastly, something a little different - a piece of clarinet music. This is the Thurston Clarinet Quartet with a piece called “Die Kunst der Klarinette” (variations on “Colonel Bogie”) by Ian Holloway. I recorded this in St. Paul’s Church in Rusthall, Kent. An MKH 30 and 40 were used in M/S configuration.

“Clarinet Carnival” Tr. 1 “Die Kunst der Klarinette” - 1’01” (Tr. 11 on Demo CD)

This was released on the ASV label, and my only complaint was, that they spelt my name wrongly on both the Thurston Clarinet Quartet CDs I recorded for them.

Thank you for listening.



REFERENCES

This paper has been written with the help of Manfred Hibbing of Sennheiser Germany who designed the symmetrical push-pull capsule and reference was made to his various papers on the subject in the process of researching this paper:-

- 1) 1752 (F-1): Manfred Hibbing, Hans-Joachim Gries: "New Investigations on Linearity Problems of Capacitor Transducers", 68th AES Convention, Hamburg, March 17-20 1981.
- 2) 2215 (E-3): Manfred Hibbing: "Design of a Low Noise Studio Condenser Microphone", 77th AES Convention, Hamburg, March 5-8 1985.
- 3) Further reading:- Manfred Hibbing: "High Quality RF Condenser Microphones" – chapter in the "Microphone Engineering Handbook", edited by Michael Gayford, published by Focal Press, Butterworth-Heinemann Ltd., London, 1994 (ISBN 0 7506 1199 5)

The demonstrations from CD are from the special Sennheiser MKH demonstration CD: SE CD 881024. The musical works are from "The Son of the Stars" Music by Erik Satie, Pianist: John Lenehan, CD: Earthsounds CDEASM 003 (now re-released on BMG by Classic FM as part of their full works series as "Satie", CD: 75605 57022 2), "Chopin, The Complete Nocturnes", Pianist: Richard Meyrick, CD: Cirrus Classics CRS CD 239, and "Clarinet Carnival" Thurston Clarinet Quartet, CD: ASV CD WHL 2095. All the music CDs were recorded by John Willett.

All diagrams and pictures
© Sennheiser *electronic* GmbH & Co. KG
Reproduced with permission

Except:
Eclipse photograph (Rechnitz, Austria - 11th August 1999)
© John Willett 1999



© John Willett 1999